

# 1120 TRIM SAW DUST COLLECTION UPGRADE

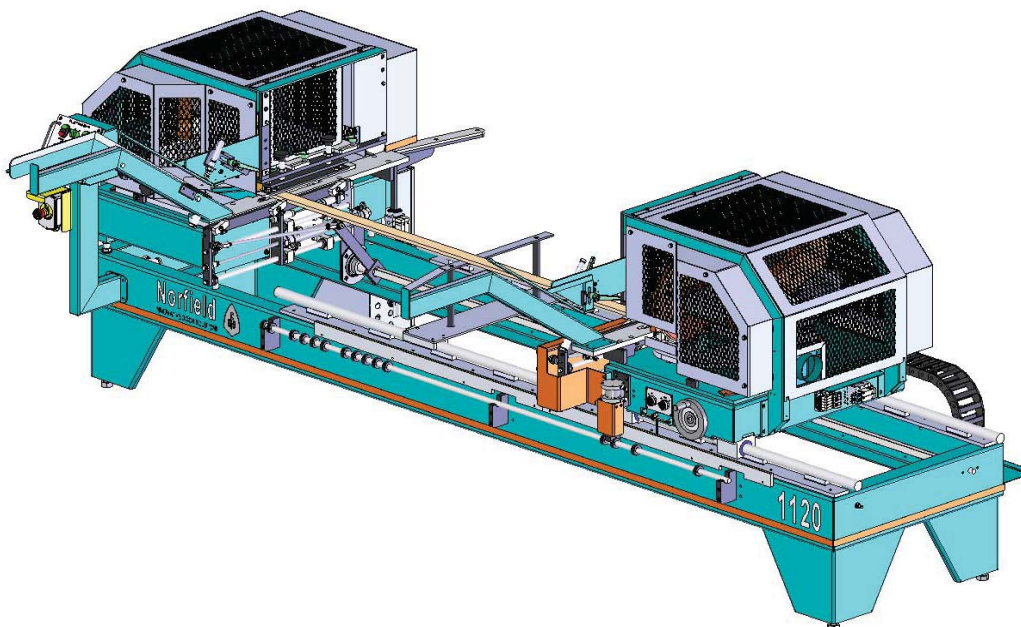

1. Remove the Top Covers from both saw assemblies.
2. Remove the existing Blade Shrouds and install the new ones.
3. Drill and tap the Arbor on each Saw Assembly for mounting the Vacuum Manifolds. (see drawing on next page for hole locations).
4. Mount the Vacuum Manifolds using the bolts and spacers provided.
5. Replace the Support Brackets on both the Movable and Stationary saws (refer to page #4).
6. Drill and tap both aluminum Turntables for mounting the Vacuum Ports. (see drawing on next page for hole locations). Note: this step is not easy - you'll need an angle head drill.

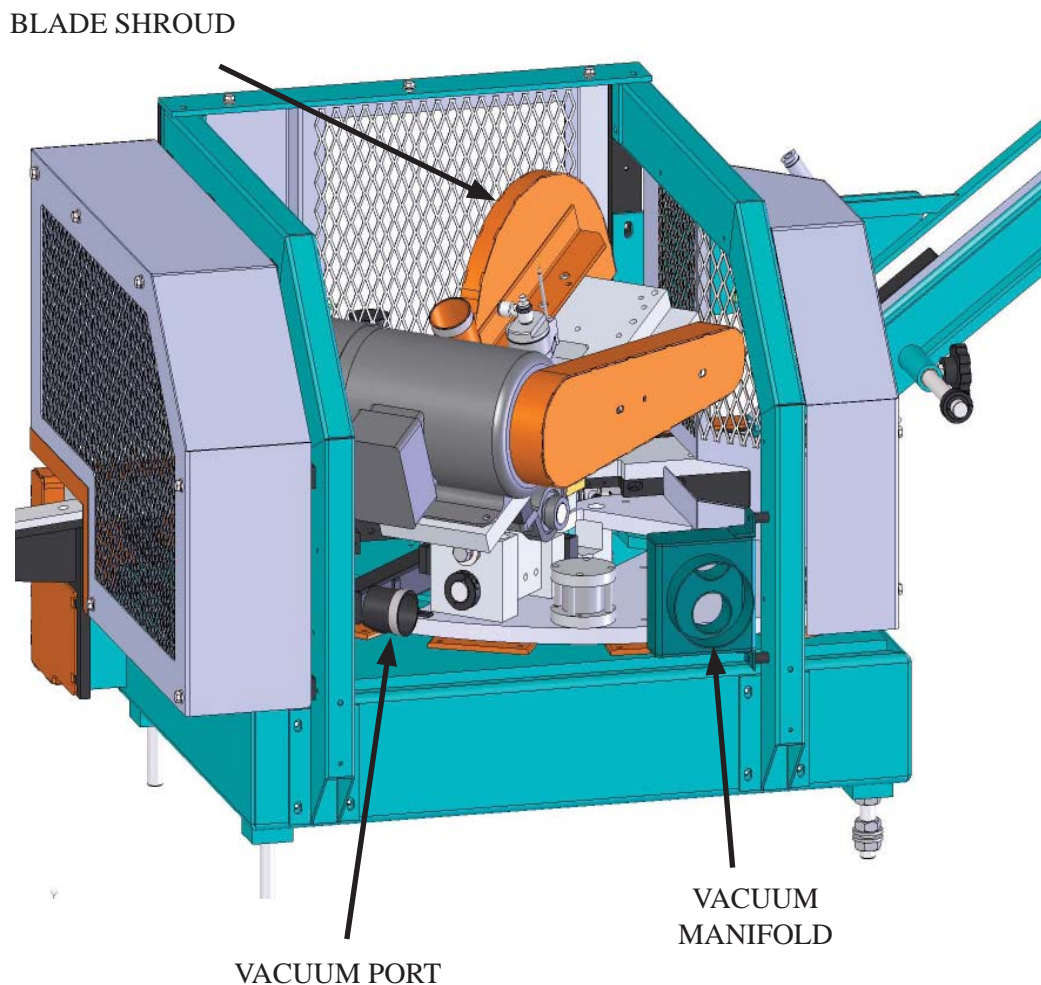

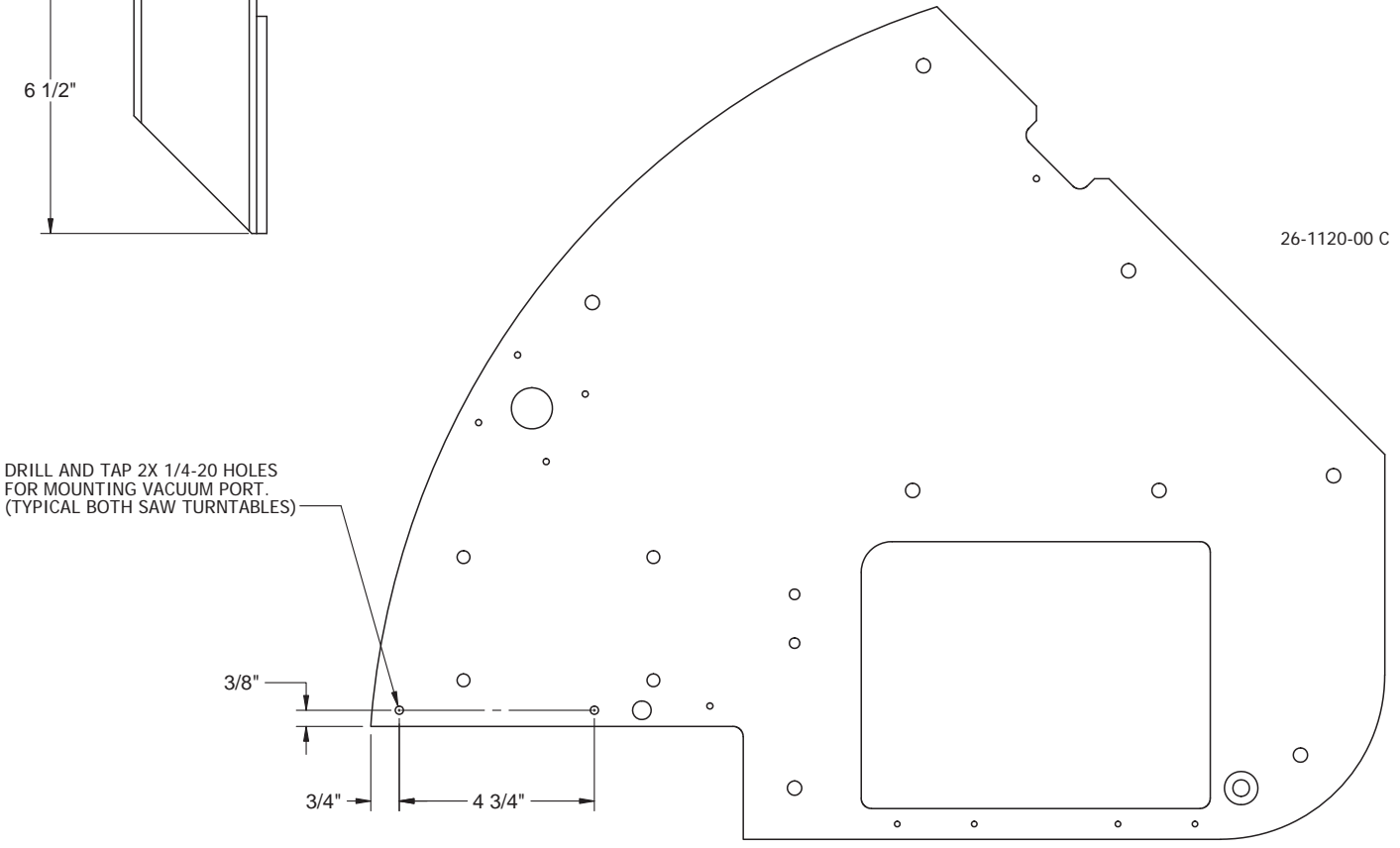
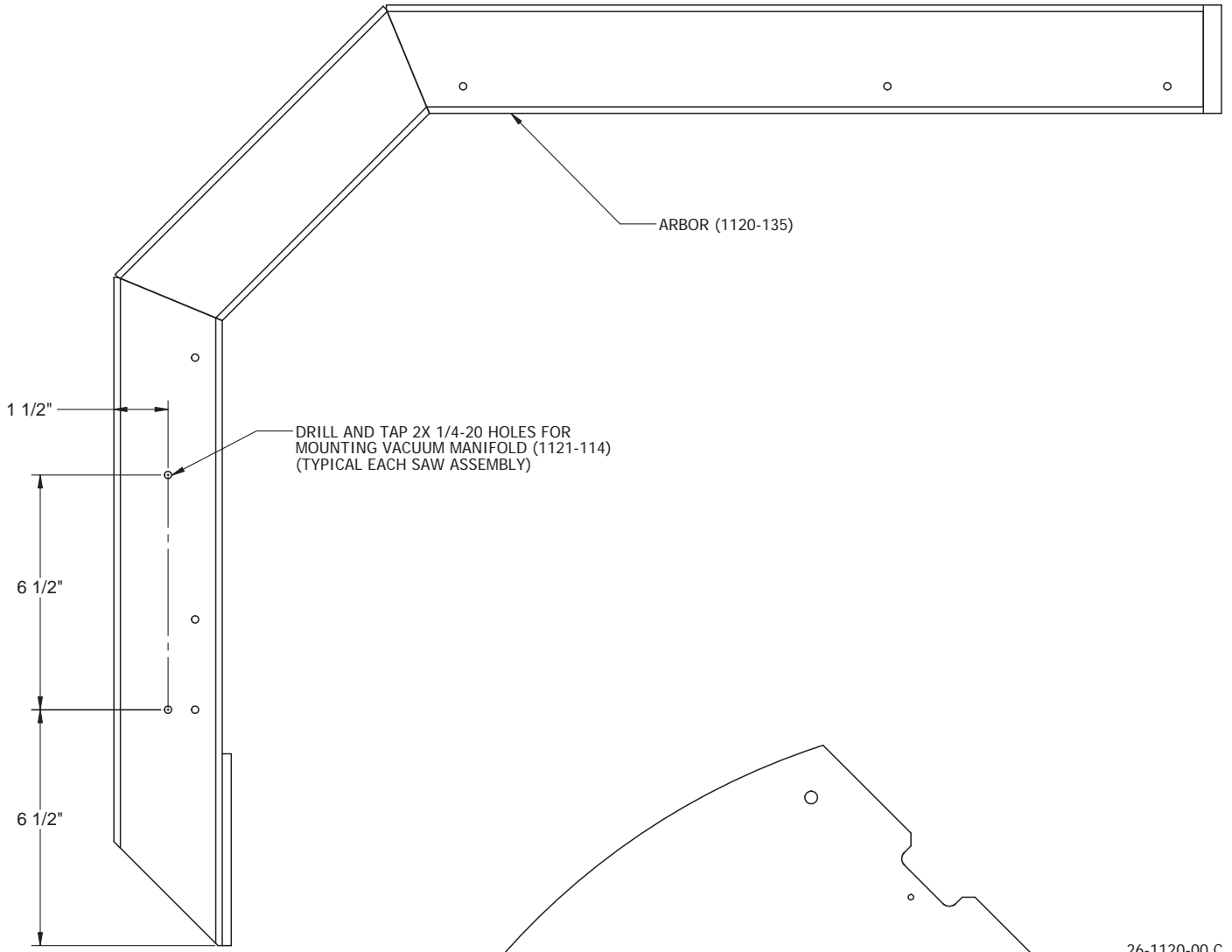

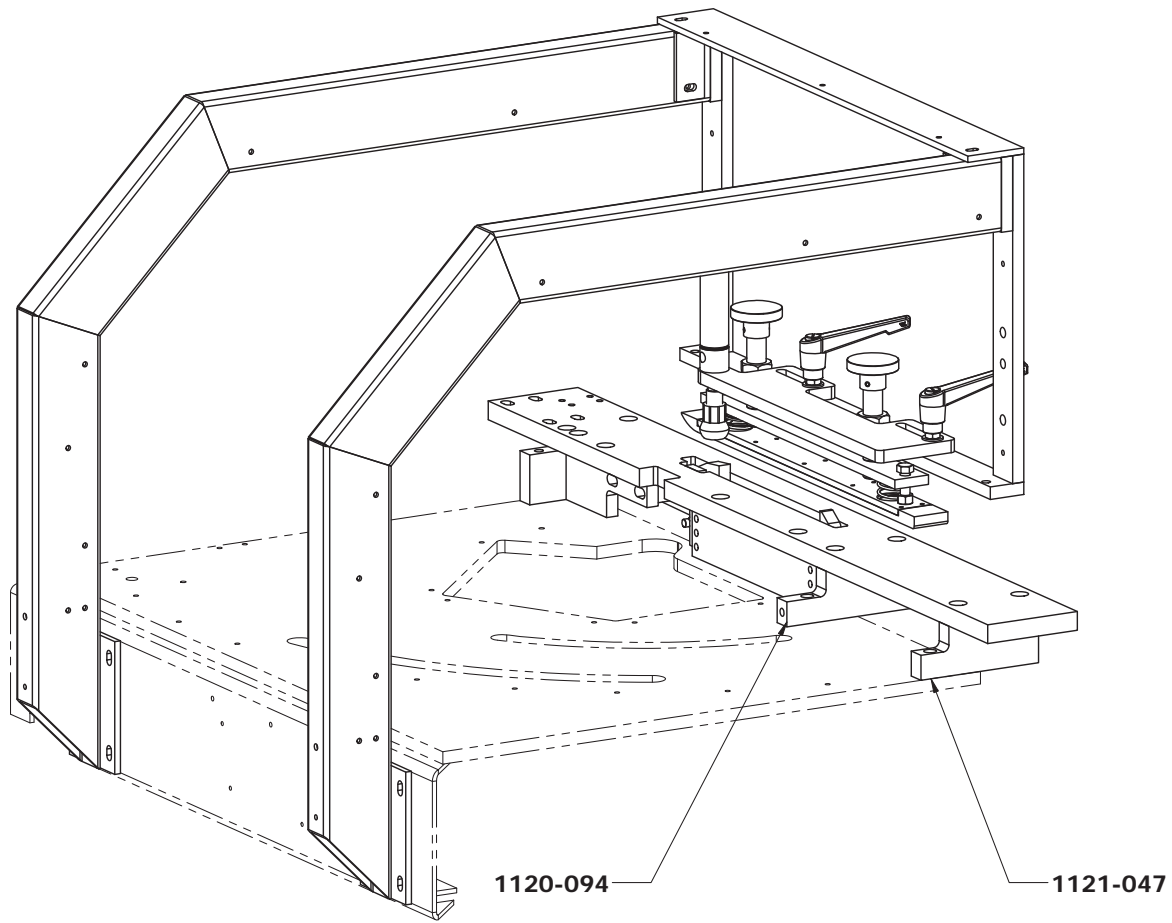

**BEFORE MOUNTING THE VACUUM PORTS (1121-112 & 1121-113) TO THE ALUMINUM TURN-TABLES, REPLACE THE EXISTING SUPPORT BRACKETS WITH THE MODIFIED ONES AS SHOWN ABOVE. THE MOVABLE SAW IS SHOWN FOR REFERENCE - THE STATIONARY SAW USES THE SAME PARTS.**

**1120-809C  
VACUUM UPGRADE**

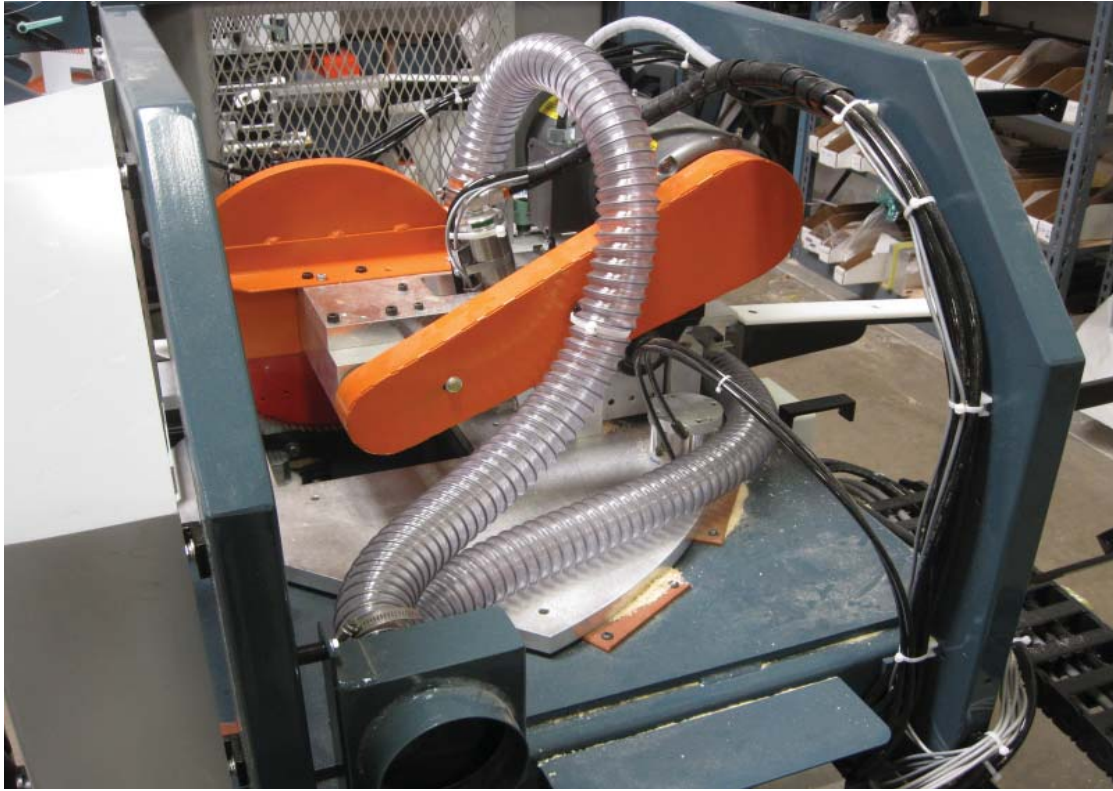

Vacuum Hose Connection  
(Movable Saw)



Vacuum Hose Connection  
(Stationary Saw)